

Collection 2023

pode

Dream away in the world of Pode



CONTENTS

72	Bibo
94	Bottle Stool
60	Cabut
44	Chap
119	Chillow
70	Colla
120	Cord
98	Edit
76	Fold
102	Insert
32	Jolt
126	Mackay
38	Marv
106	Melloo
48	Mesh
121	Nastro
92	Nihan
18	Nivti
116	Osun
86	Ova
117	Pom
124	Puff
125	Punto
115	Pylaz
122	Rye
118	Shallow
82	Sparkle
84	Spot
127	Swell
128	Tab
110	Transit
26	Tresto
96	Tripod
62	Tubble
54	Turia
90	Unda
114	Uturn



Your perfect interior with Pode

Nothing is more personal than perfection. We've all got our own ideas about what constitutes a perfect interior. At Pode, we do everything we can to turn yours into reality with the help of our talented designers and the expertise of our skilled craftspeople. And we hope you'll find exactly what you want from us. Your dream sofa or an armchair to envelop you. That glamorous table or the accessory that pulls it all together. This is what we dream about. Our place in your perfect interior.



Why Pode is right for you

Wood, foam, springs, upholstery; you could say that it's the materials that make Pode furniture so comfortable. There's some truth to it, but it's more than that. At Pode, you choose so much more than just a piece of furniture. And that makes it all the lovelier.

Lifestyle collection

A common theme runs through the Pode collection, which gives it a subtle balance. Our furniture, accessories and materials complement one another perfectly in image, colour and feel. To let you make beautiful pairings. We collaborate with top international designers and renowned suppliers of upholstery fabrics and other materials like wood and ceramics. Our art directors, Claire and Roderick Vos, play an important role in this process, ensuring that Pode always retains its unique and quirky look.

Comfort and quality

Pode products are well made. Really well made. You'll notice it when you first sit down, and for many years to come. Experience the craftsmanship and decades of experience of our parent company, Leolux Furniture Group. This expertise dates back to 1934 and is a guarantee of the exceptionally high quality of our manufacturing premises in Venlo (The Netherlands) and Szolnok (Hungary).

Your Pode

Every piece of Pode furniture is bespoke. This gives you the ultimate freedom. You can dream up endless combinations from the models, materials, and options in the Pode collection. And fortunately, we have a large network of expert dealers to whom you can turn for professional and personalised guidance. Or visit our showroom in the Leolux Experience Center in Breukelen (NL). You'll find more Pode furniture there than anywhere else! And we'll still stay available to you after your purchase. We provide you the extra security of a seven-year warranty.

Where high-tech and
artisanship meet.



Meet the makers

Nothing is more satisfying than making something new with your hands. Just ask our Pode craftspeople. Every day, they make the most beautiful Pode creations in Venlo (Netherlands) and Szolnok (Hungary). Their craftsmanship is combined with cutting-edge techniques for the very best results. In Pode's manufacturing, human and machine have their own roles to play.

The comfort maker

In the pre-upholstery department, Sander and his colleagues ensure your furniture is comfortable. They attach different sorts of foam to the frame for a perfect balance between support and give.

Human

Furniture making is a craft. And at every step of its journey, your Pode piece 'travels' through the hands of talented makers: woodworkers, warehouse staff, frame builders, upholsterers, fabric experts, coverers, finishers, packers and movers. They turn your Pode product into much more than simply a piece of furniture. They create monuments of human ingenuity.

Machine

To be fair, our machines deserve recognition too. For our people to execute their craft to the highest standards, the support of high-quality technology is essential. In everything from sawing pieces of wood to cutting large quantities of fabric or leather. Most of the time, we put our trust in the precision of our advanced machines for these heavy jobs. Sometimes a little human intervention is called for too...

Man and machine
excel at exactly
the right time.



The upholsterer

All the elements of a piece of a furniture come together at the coverer's, where Klim attaches the covers to the frame. He also adds the under piece and any other parts required to make a finished piece of furniture.

The frame-builder

We want to ensure that you can continue sitting comfortably on your PODE furniture for years to come. And that demands an indestructible construction. Therefore, Daan and his colleagues from frame building only use the best materials to construct their super-strong frames.

The designers designing tomorrow's Pode

Art directors Claire and
Roderick Vos Pode's
language of forms





“We choose for forms which will maintain their appeal and allure going forward.”

When you put together a contemporary collection, you have to look beyond a single model. You look to build relationships between the different designs to give your collection its own, distinctive look. At PODE, this role is in the hands of art directors Claire and Roderick Vos. They have been providing the collection with its direction and brand image since 2016. A role that has grown in complexity and become increasingly interesting as a result.

Softer and rounder

“When we started out, the PODE brand still needed to develop its own look. And the collection too”, says Roderick. “If you looked at the models, you saw a strong geometric language of form. Lots of straight lines and hard angles. But over the last years we have been looking towards softer forms. Fewer straight lines, curvier shapes, rounded corners. You can see that well in the Cabut and Bibo armchairs and in the Colla and Turia sofas. With a brand like PODE, you need to carry out this sort of transformation from a long-term perspective. We make high-end products to last. And that means a product’s form needs to stay relevant and serviceable over the years. PODE is no manufacturer of trendy products. We make conscious choices for forms which will maintain their appeal and allure going forward.”

Added value

Our way of working has changed to reflect the timelessness of our designs. Says Claire, “It was easier when we started out. We wanted to make things that didn’t yet exist. But now that the ‘missing’ models have been added, we have to look carefully for the ‘gaps’ in our collection. What sort of furniture or product would really add value to the collection? We weigh up a number of different matters. Innovation, commercial viability, identity, and above all intuition; every model is born out of the needs and opportunities that these factors present.”

Beyond borders

Of course, it’s Roderick and Claire who are the creative force behind the essential, successful PODE models. But in their roles as art directors, discovering new designers is almost more important. “If you want innovative designs, you have to work with innovative designers,” says Roderick. People with the talent to develop PODE further. If you develop something that is totally PODE right now, you’re already too late. We are looking for designers who can design the PODE of tomorrow. And they could be anywhere. Therefore, we’re trying to look beyond our borders. For example, you can see that designers like Yonoh Studio and Meike Hard both add a completely different language of design, so that we get that exact mix of styles that we’re looking for at PODE. We don’t view PODE as a Dutch brand, but as an international one. That’s what we’re striving for, and if that’s what you want, you have to work with international designers too.”

Antennas

Intuition is very important. Particularly when you’re trying to identify how people want to live and how the PODE collection can respond to this. “In 2016, we saw that soft organic forms were starting to get the upper hand. And roughly two years ago, people started to play around more daringly with their sofas, to make better use of their interior space. Our antennas are always out trying to spot such developments. On social media and when we travel, of course, but truth be told, every second of the day. And with the arrival of our very first PODE showroom in the Leolux Experience Center in Breukelen, we have added a wonderful extra radar. That’s where we can observe the purest reactions. And based on direct feedback, we can determine the next step for PODE.”

Feel-good upholstery

You may not notice it immediately when you're sitting comfortably and enjoying your new sofa or chair, but your Pode furniture is manufactured with great care for both people and the environment. Sustainability plays an important role in every choice we make. And if you think like us, our 'responsible choices' are the way to go.

Sustainability is an essential part of our furniture. Everything from its timeless appearance to a quality you can enjoy for years. We do all we can to manufacture as cleanly and efficiently as possible and to reduce our carbon footprint. This ranges from cleaner manufacturing methods to more efficient machines, a reduction in materials' usage, generating our own solar power, energy-efficient buildings and greener transport. Naturally, our ambitions in the field of sustainability play an important role in our relationships with our suppliers too. Like when it comes to covers. We introduced our 'responsible choices' last year. A range of beautiful furnishing fabrics with which you can make your Pode furniture that bit more sustainable. So, for example, we offer several sorts of artificial leather. A perfect option if you love the look and feel of leather but have consciously

opted for a cruelty-free lifestyle. Increasing numbers of fabric suppliers are committed to making beautiful and sustainable fabrics. Developments are happening fast and are making their way into our fabric choices. This means you can opt for a fabric made 100% from PET bottles. Or a fabric from ocean plastic waste. And the best thing about it is that you'd never notice any of this while simply enjoying your furniture. Thanks to the creativity and innovation of suppliers like De Ploeg, Maharam, Skai, Kvadrat and Reviva these responsible choices do not fall short of other furnishing fabrics in terms of feel, colour or quality. And that's why we're such fans.

How about you? Will you take the responsible choice for your next Pode piece?

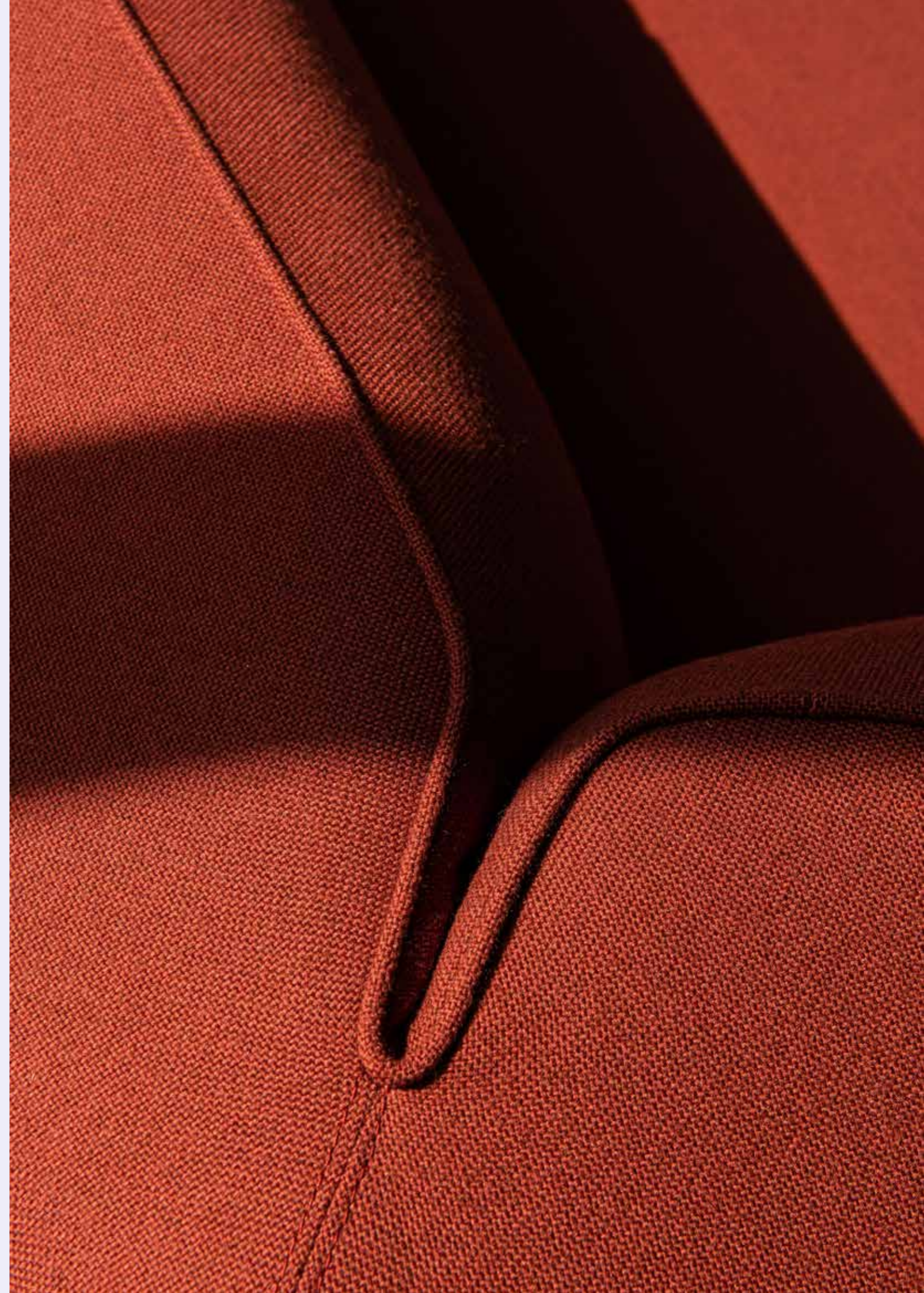



Our models and their makers

Collection and designers

LOUNGING AROUND

NIVTI





If you like your seating that little bit deeper and lower, you'll love the wonderful Nivti, by PODE. This model is designed by Meike Harde, who has created a range of distinctive-looking sofas and add-ons that you can approach from any direction. There's a beautifully compact two-seater, a huge corner sofa with a chaise longue, and everything in between.



NIVTI



The best place
to relax



MEIKE HARDE

Meike Harde has already been nominated no less than twice as “Best Newcomer” for the renowned German Design Award. The work of the talented designer, who founded her own design studio in Cologne in 2013, ranges from textiles and lighting to decorative materials and furniture. Perhaps that is why it is not so easy to pigeonhole her work.

Nevertheless, there are many points of reference, she says: ‘I am very precise in everything I do in my work. With my technical understanding and my love of natural materials, I design products that are visually light and cleverly constructed’. The results are playful products with a poetic character. ‘I find it very interesting to approach existing production techniques in a different way and to put ordinary materials in a new context’. Through this experimental approach to the design profession, she succeeds in developing a new design language that perfectly matches Pode’s ideas.

TRESTO





It's fair to say that Tresto is very spacious. With its big shell and comfortable seat and back cushions, it's ideal for some 'me' time after a long day – or even a short one. The frame beneath the shell is a real eyecatcher, available in every colour under the sun. Black, bright red, fresh green: with Tresto, the choice is yours.



Ideal for some
'me' time



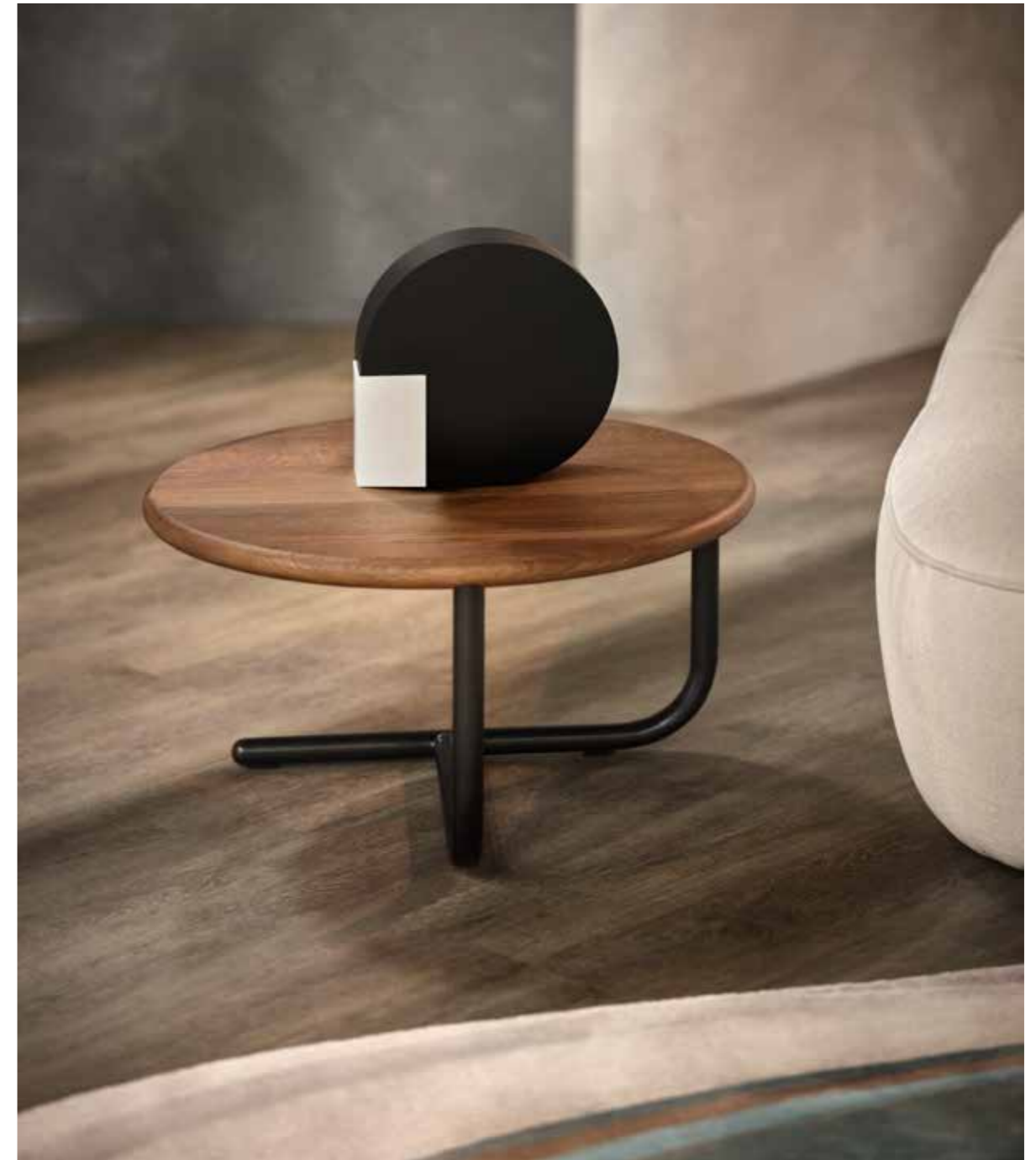

You can tell Jolt tables are durable just by looking at them. With their three-centimetre-thick, large-radius tops and sturdy tubular frames, they're built to last - but not so heavy that they're difficult to lift. The different heights, shapes and sizes of Jolt tables make them easy to combine, and the lowest version, at just 29 centimetres high, is a great fit for low-seat sofas or chairs. PODE is all about slow, low, and lazy - and we hope you are too.

JOLT

Built
to last



Yonoh was founded in 2006 in Valencia, where the duo studied and still have a studio. They have a broad-based portfolio that includes house styles, exhibition stands and numerous consumer items. "But," admits Selma, "interiors are closest to our hearts. It's where we eat and spend time with our loved ones but also where we work more and more often. It's where the full life takes place, you could say. With furniture, we give substance to that life. It's why many of our designs have a friendly and generous look. They fit in a modern interior but also in interiors with a more classical style.



MARV

Sofa Marv Table Mesh Rug Nastro



Linear and wavy lines
converge to form an
'organic cubist'

Roderick Vos, 2021

MARV



Sofa Marv Table Mesh Lamp Pom Rug Nastro



Marv is a tuxedo sofa. Elegant and timeless, in which linear and wavy lines converge to form an 'organic cubist', according to designer Roderick Vos. He started with the 'monoblock' and cut away all excess materials. The result is powerful and compact seating with pure lines. Marv is the perfect family sofa that you can place in the centre of the room or against the wall.



Armchairs Chap Sofa Marv Rug Nastro

Table Mesh Lamp Osun

C N

Federica Biasi, 2021

A P



CHAP

Relaxing curves with a dash of retro - that's what Chap has to offer; the ultimate friendly armchair. So friendly with its compact form that fits really easily in pairs within your interior. Because the more chairs, the more joy. And Chap is a friend you like having around.



A game of openness and density



MESH

Raw Color, 2021

MESH



Raw Color's Choice: Coffee table Mesh Table-top lacquer Cedar Frame lacquer Forest
Occasional table Mesh Table-top lacquer Teal Frame lacquer Brick



An interaction of
densities and
material combinations

In the Mesh table series, design studio Raw Color plays with the density of colour and material. Open and closed alternate in the perforation grid. This gives the tables an airy look, in which the table top appears to be separate from the base. At the same time, the graphic character of Mesh creates an interesting shadow effect on the floor. The design reflects the Raw Color working method, in which the colour effect of the volume forms the starting point, in this case for the interplay of densities and material combinations.

A versatile look

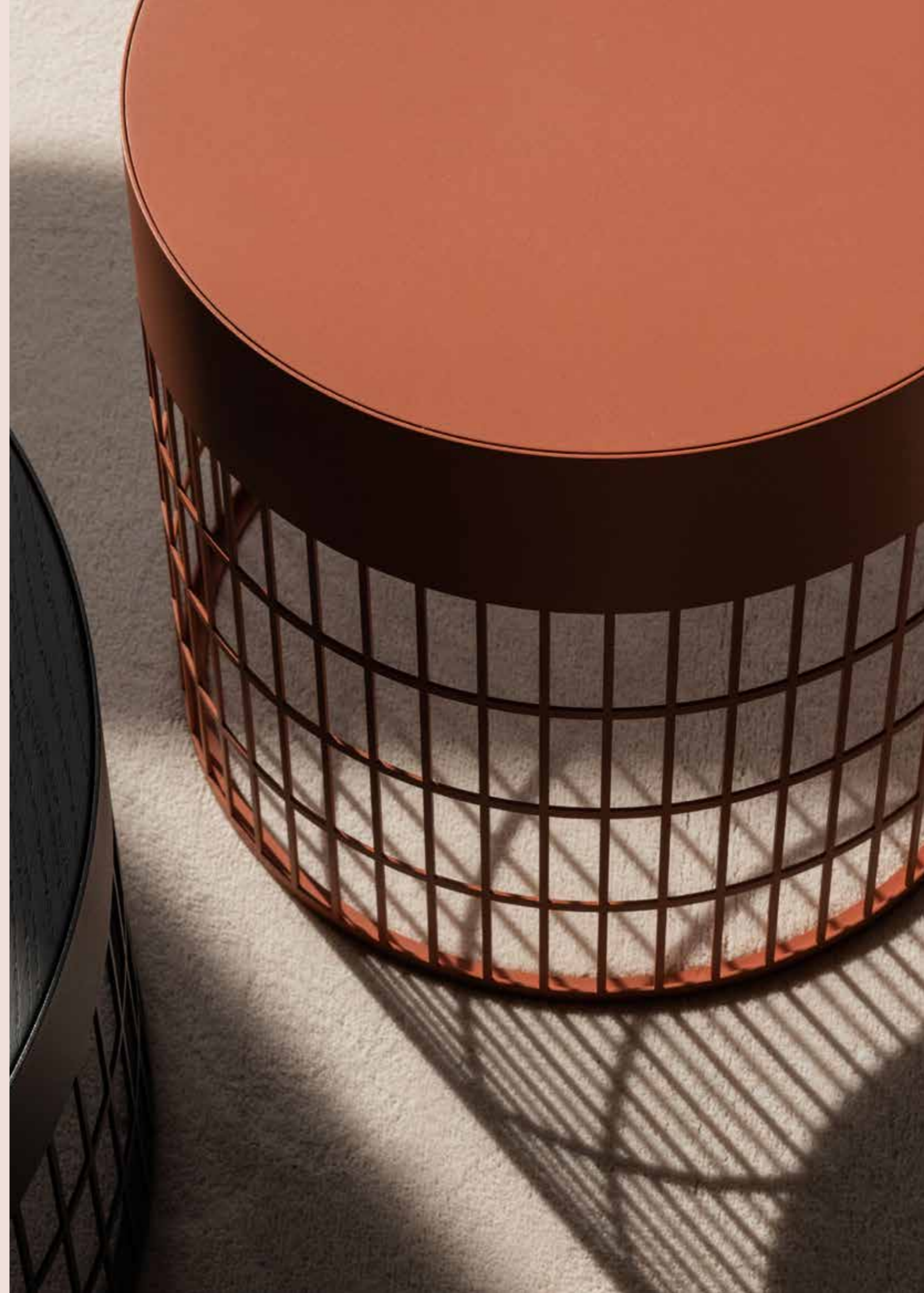

TURIA &

Sofa Turia Armchair Cabut Rug Nastro



CABUT

Yonoh, 2020

TURIA

A Valencian vision on comfort

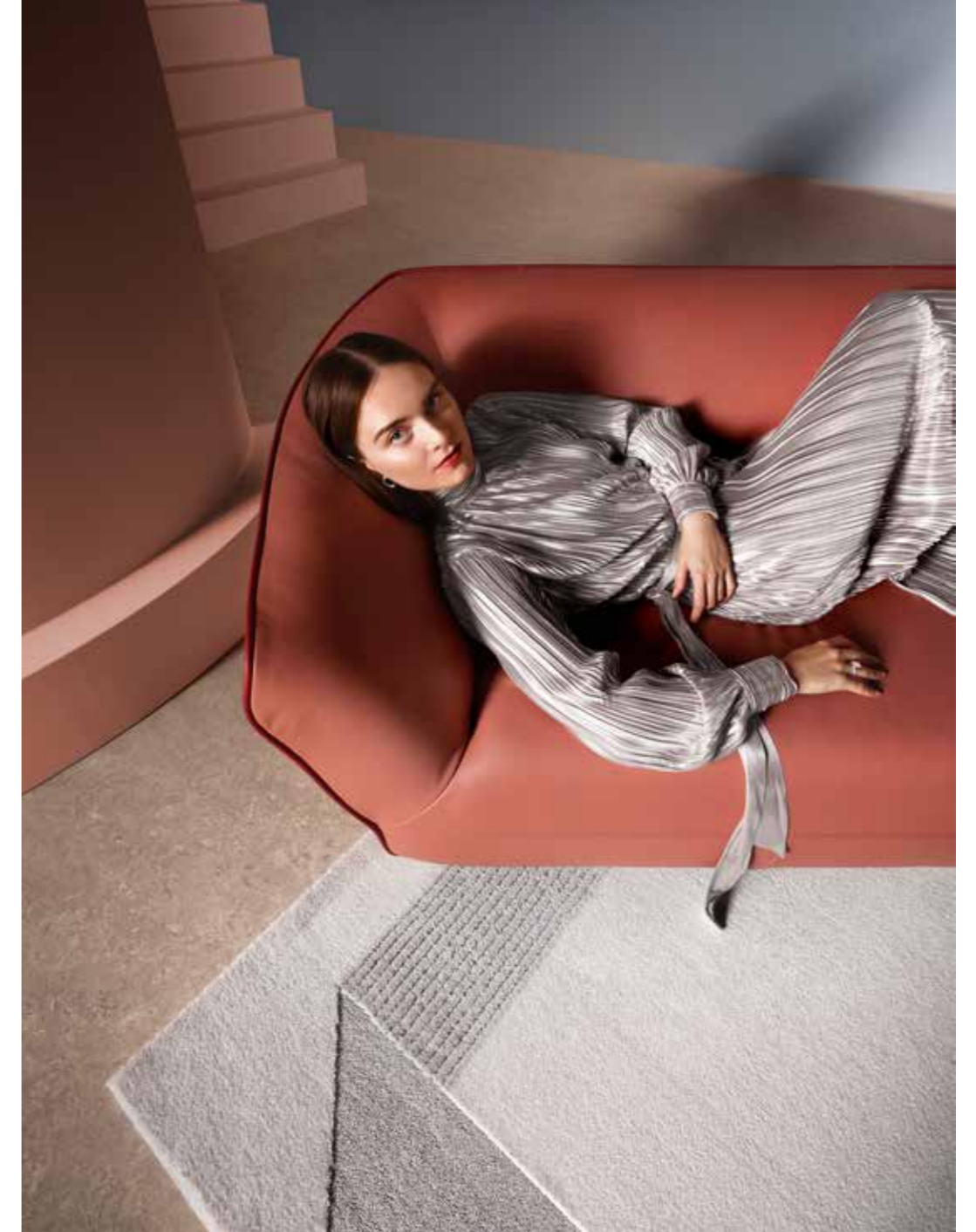

A Valencian vision on comfort - that is Turia. It's not without reason that the sofa programme is named after the river that meanders through the city. It is designed by design studio Yonoh and is just as great a place to hang out as Valencia itself. If you look at the design, you see an exciting mix of beautiful, rounded forms and sharp lines. This gives Turia a really personal look, while also being essential for comfort, because the sofa programme has snug corners into which you can comfortably retreat. Put your feet up on the chaise longue and relax - what more could you wish for?



A mix of beautiful, rounded forms and sharp lines

CABUT

Innovative and original,
with an unerring eye for detail.



Armchair Cabut



Cabut is the result of our first collaboration with the Spanish designer studio Yonoh. It represents Spanish design without any unnecessary frills. This comfortable and inviting armchair is a classic example of their characteristic designer style: innovative and original, with an unerring eye for detail. One instance of this is the striking piping that continues across the entire design. The armrests are tilted slightly outwards and gently support your arms, while the entire armchair rests firmly on four simple legs.

A nice, stylish look and numerous material and colour options.



TUBBLE

The Tubble table series from Roderick Vos is anything but simple and straightforward. The stunning organic leaf shape has a nice, stylish look. If you have two, they are perfect pushed together. Or beneath each other, if you go for two different heights. And, of course, there are numerous material and colour options. For instance, three beautiful shades of marble quartz: Calacatta, Grigio Carnico, Verde Tirreno and Fior Di Pesco. You can also choose solid oak in all PODE wood stain colours or a lacquered version.



Armchair Bibo Coffee table Tubble Sofa Colla Occasional table Ova Footstool Unda



Federica Biasi

Federica Biasi is an Italian designer, but that description actually doesn't do her justice. After graduating cum laude from Milan's European Institute of Design in 2011, Federica set her sights on the whole world. She also lived in the Netherlands for two years, immersing herself in North European design.

Meet the designers



Kranen/Gille

Jos Kranen and Johannes Gille know each other from the Design Academy in Eindhoven. They graduated in 2004 in the heyday of the academy, when it was all about progress and innovation. Three years later, they set up the Kranen/Gille design studio in 's-Hertogenbosch (NL).

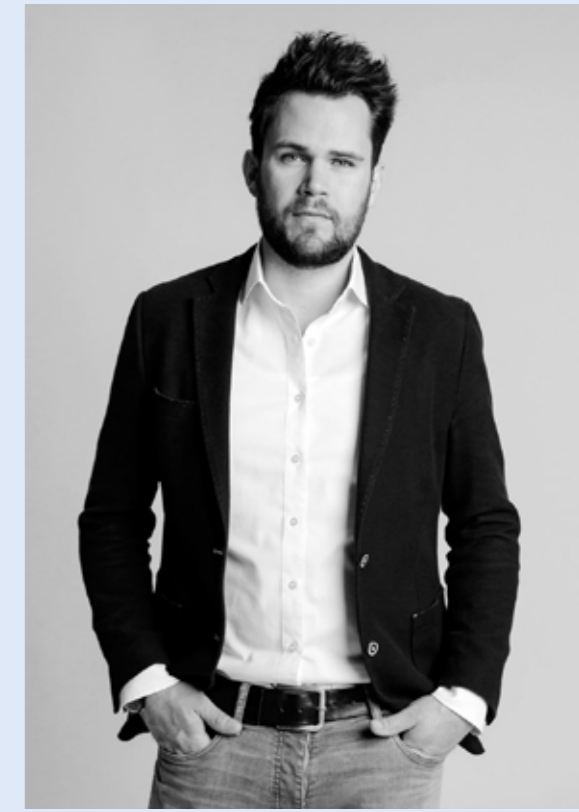

Pascal Bosetti

Pascal Bosetti (1981) studied in Basel, works in Munich, teaches in Cologne and –on top of it all– speaks excellent Dutch. For several years he has been designing products for the Poda collection. We can undoubtedly speak of a very versatile designer.

Michael Raasch

German designer Michael Raasch earned his spurs long ago, but he is still fascinated by the design process. You start with nothing, just an idea or a problem. And as the process progresses, something emerges that wasn't there before, something which is shaped purely by the creativity required to resolve the challenges between form, function and technique. That's always exciting.



Susanne de Graef

Susanne de Graef is based in Eindhoven (The Netherlands) and as a designer, she has a sincere predilection for textile and light. Detailing and tactility play a vital role and she isn't the type of designer that goes in for extravagant decorations and other excesses. "A good piece of furniture can be combined with a table or an armchair in a completely different style."



Raw Color

For Christoph Brach and Daniera ter Haar colour is key, but they're not only involved with product design. Their interest extends much further, from graphic design and photography to textiles, with well-known fabric specialists Kvadrat and Febrik being among their clients.

Jet Dircks

Jet Dircks is the only designer who works at Poda on a permanent basis. However, she does much more than design. She selects other designers, gives briefings, maintains contacts, and gives feedback during the design process. It was she who designed the Edit and the Insert.



Roderick & Claire Vos

Claire and Roderick Vos have known each other since they studied together at the Eindhoven Design Academy in the 1990s. Since 1999, they have worked together at Studio Roderick Vos. "At Poda we watch over the consistency of the collection, asking questions such as: Is a design compatible with the existing products? Which items of furniture are still missing? And in that way we build on that Poda DNA."

Thijs Smeets

Thijs Smeets studied Industrial Product Design at The Hague University of Applied Sciences. He has now been running his own company for 13 years: Studio Smeets Design, based in a wonderful art nouveau building in the centre of Amsterdam, with a view of the Westertoren. For Poda, he has the swivel armchairs Spot and Sparkle.



Stephan Veit

After graduating from the University of Kassel, Stephan Veit worked as a research assistant in the field of computer-aided design and visualisation. In 2002 he started his own design agency in Stuttgart. Stephan Veit Produktdesign works for various well-known furniture industry brands, including Poda.

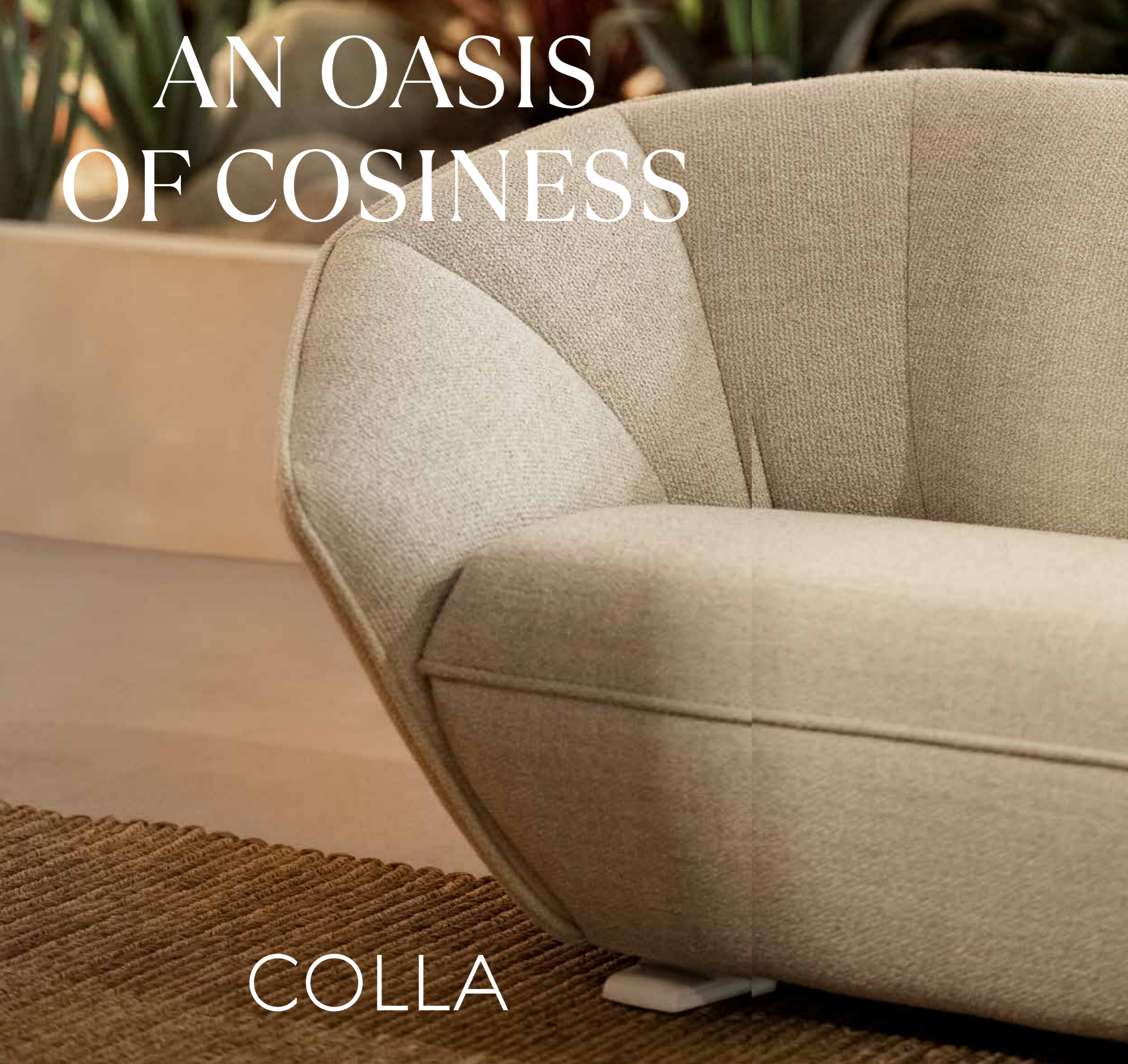

AN OASIS OF COSINESS

Susanne de Graef, 2019

COLLA

Find your place in Colla and surround yourself with pure Pode design. Colla is a design by the Dutch designer Susanne de Graef and creates an oasis of cosiness in your interior. With delightful corners as a trademark, this sofa is perfect for sharing or for claiming it all for yourself.

B I

Roderick Vos, 2020

B O





BIBO

Welcomes you
with open arms



Bibo is unquestionably one of the most charming members of the Pode collection. It welcomes you with open arms and provides you with hours on end of comfortable seating. It is equipped with a solid swivel base with four legs, which looks good as well. And you can choose the exact version you want, just like all our other Pode products. You can opt for leather or fabric in one colour, or maybe you'd prefer your Bibo in a unique combination that fits in perfectly with your interior.

FOLD

Sofa programme Fold



AN ODE TO SIMPLICITY

Roderick Vos, 2016

FOLD

Roderick Vos: "With this design, I was aiming to create a sturdy family sofa, a sofa for young and old. Design to be enjoyed. In every sense of the word. This innovative and timeless sofa was created by Folding the upholstery fabric and cutting it as little as possible. Hence its name: Fold. I have a preference for comfortable cushion sofas, but for this design I actually avoided the image of 'loose cushions', giving rise to a lovely abstract sofa with no excessive details."

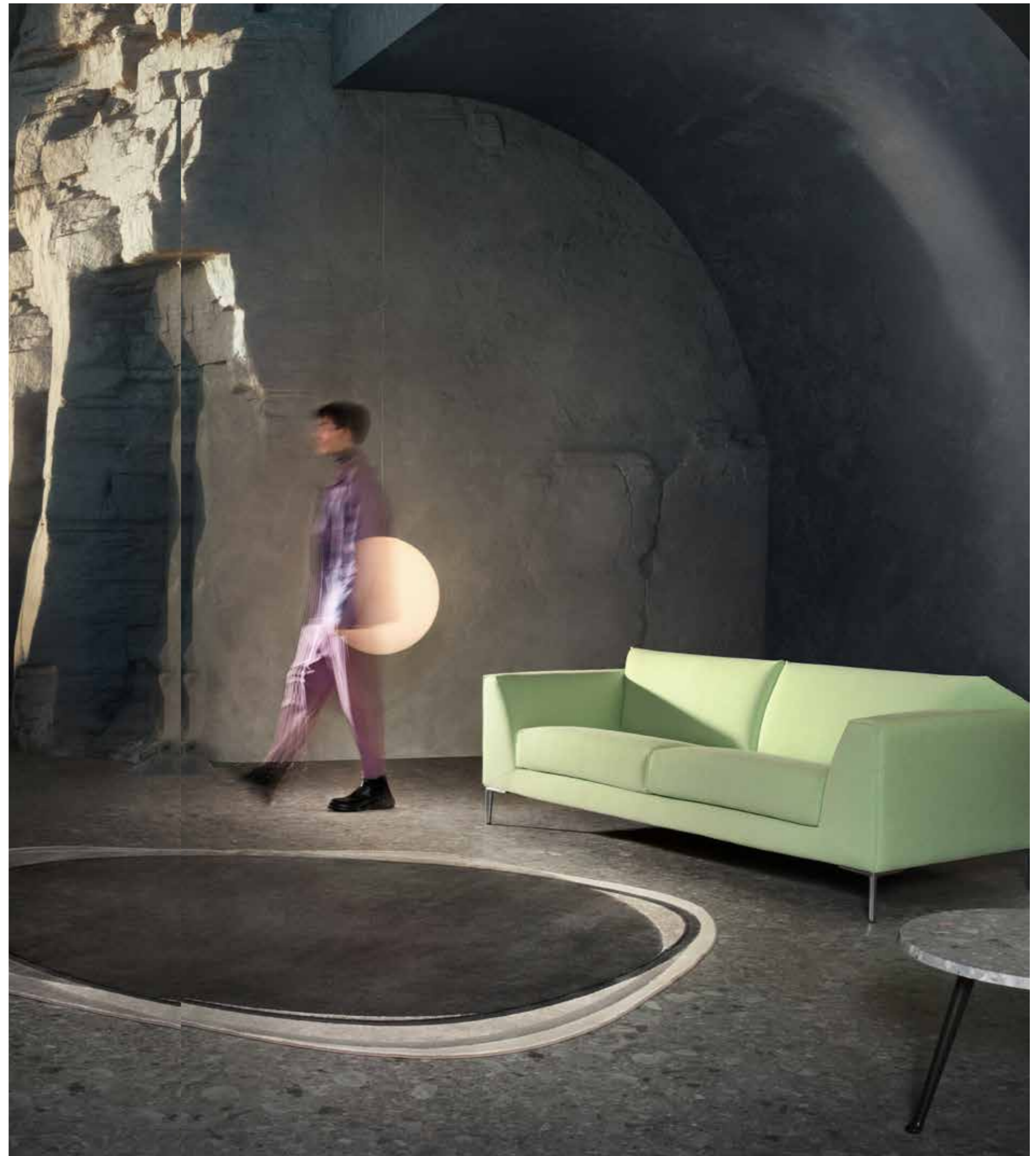

Understated design



Fold - fabric Monza 44

SPARKLE



A lovely modern armchair that has a bold retro look

A splendid swivel armchair with a strong retro look: Sparkle. By varying the colours of the body, the seat cushion, the swivel base and the decorative stitches, you can create audacious combinations. Colour-to-colour or vividly contrasting. The high Sparkle TWO version gives the design a sense of grandeur and offers even more comfort than the existing low version.

This Smeets, 2014

SPOT



Spot gives you a wonderful family feeling, just like so many other Pode products. This is even more the case with this beautiful swivel chair, especially, because Spot is a full cousin of our Sparkle. Despite the clearly recognisable family lines drawn by Thijs Smeets, Spot is unique. The seat has fixed upholstery, for example, without a loose cushion, giving it a very different look.



Thijs Smeets, 2019

OVA

&

Footstool Unda Occasional table Ova



UNDA

Meike Harde, 2020

The asymmetry
gives Ova
a really special look



The understated table series Ova takes stylish design enthusiasts on a voyage of discovery. Because the longer you look at it, the more you see the beautiful details that Cologne designer Meike Harde has added to her design. For instance, each table has two different types of legs. This asymmetry gives Ova a really special look.



UNDA

Unda forms a dream team with Ova

Footstool Unda Occasional table Ova



Unda is officially designated as a footstool. But in practice this Meike Harde design offers much more than just a place to rest your feet. The Unda's strong internal construction means you can also use it as an additional and comfortable seat. The footstool is finished with a thick layer of high-quality foam especially for this, so that you can experience true Pode comfort. For the upholstery, you can choose from all fabrics and leathers in our collection.

NIHAN

Pascal Bosetti, 2017



Nihan is wonderfully laid back: it's an armchair you can really relax in. And have you already discovered the inventive details? The stylish joint between the back and frame, which conceals all the fastening materials. And the frame itself; it's not as simple as it looks either, with its subtle curves that perfectly match the fluid shape of the seat and the back.

It's a winebottle holder, a stool and a cheese plank all rolled into one

The Bottle Stool designed by Kranen/Gille was a huge success from the moment it was introduced. It's a winebottle holder, a stool and a cheese plank all rolled into one, but above all it's a table that can't help but attract everybody's attention.

The Bottle Stool is handy and mobile because the 'ring' that holds the winebottle can also be used as a handgrip. Jos Kranen and Johannes Gille have managed to combine an impressive number of functions in one design.



Kranen/Gille, 2017

BOTTLE STOOL

Three legs with two kinks
that merge together
at a single point

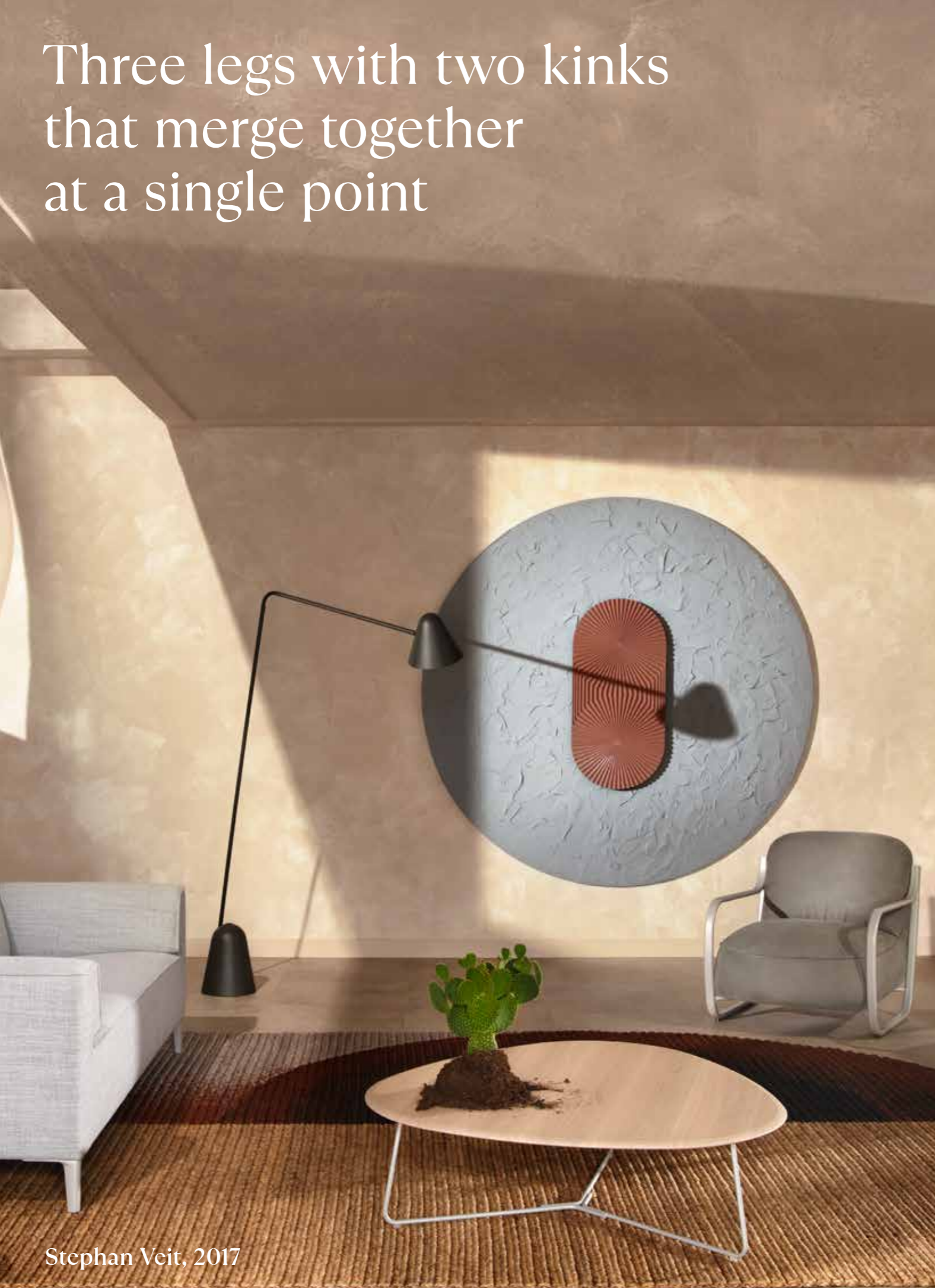

Stephan Veit, 2017

TRIPOD



The name only tells half the story. This series of coffee and occasional-tables does indeed have three legs, each with two kinks so that they merge together at a single point. But Tripod is more than that: the industrial base supports a beautifully crafted triangular table-top with gentle curves. And the combinations of different sizes, heights and finishes are also very handy.

Super in fabric, fantastic in leather!
Or a combination of fabric with
leather piping. The sleek Edit design
sofa fits everywhere, even in the most
functional interior. With a little bit of
colour, Edit is suddenly transformed.
Also available with matching ottoman.

Sofa Edit Tables Mesh Footstool Unda Rug Nastro



Jet Dircks, 2008

EDIT

EDIT



From warm and cosy
to streamlined and stylish

LOVELY LOUNGE AREA

Armchair Spot Tables Tubble Rug Mackay Sofa programme Insert Lamp Pylaz



Insert feels at home in every interior. From warm and cosy to streamlined and stylish. The sofa is available in fabric and leather and, for that personal touch, you can have the distinctive piping finished in a different colour or material. Do you dare to use a bold colour combination? Then Insert is your canvas.

Jet Dircks, 2008

INSERT

At home in
every interior



Sofa programme Melloo Occasional table Mesh Footstool Unda Rug Rye



Build your own
comfortable
Melloo landscape

MELLOO

Roderick Vos, 2017

MELLOO

The world of Melloo revolves around you. With many sofas, elements and a matching footstool, you can compile this friendly and inviting Roderick Vos design exactly as you want it. The modular sofa programme challenges you to give your creativity free rein. Melloo is unique thanks to the round corner unit that you can use to build your own comfortable Melloo landscape. And of course, you can also select rightangled corners. Add a lounge element so that you can relax at full stretch, or extra seating elements so that friends and family can enjoy the sofa with you. Melloo is the most complete range in our collection, with all the use options you need for your interior.



Unleash your
creativity

An armchair
with character



Roderick Vos, 2016

TRANSIT



Sometimes, sitting down feels almost too good. In the Transit armchair, designer Roderick Vos subtly combines shape and comfort. With sleek lines, a floating seat and legs made of curved pipe material, but above all casual, loose upholstery. Transit is available with a high or low back, a choice that influences both the appearance and the degree of comfort. Whatever suits you best. And do you know what also looks fantastic? Two armchairs beside each other. The perfect picture!



The loveliest extra

Lighting and accessories

PODE

UTURN



Highlight
your treasures

Has a lamp ever bowed deeply to you? Well, Uturn does. The royal bow in this striking light connects a table-top with a subtle spotlight. Ideal for highlighting a nice souvenir or any other treasured item. Only available with euro plug.

Michael Raasch, 2018

Pylaz is a personal butler light. With the flexible frame and the option to turn and tilt the shade, Pylaz makes it easy to provide lighting exactly where you want, whether you're reading or you need additional accented lighting for a visitor. Pylaz is the ideal mood lighting. Only available with euro plug.



Michael Raasch, 2018

PYLAZ

OSUN



If you don't want simple, direct lighting, Osun is the perfect lamp for your interior. Because it has three separate rings that together bathe your living room - or any other room - with a very pleasant light. And you'll be glad to hear that Osun is supplied with a dimmer as standard. That way, you can set exactly the amount of light you want - from a soft shine to a giant ring of fire.

Michael Raasch, 2019

Pom provides you with vibrant light at any moment. If you want to lose yourself in a book in the dark hours, for example. But also if you have a dark corner in your living room, where you wish to create a stylish light source. Pom stands alone on a lovely firm base. You can turn and tilt the shade to direct the light wherever you want it. Only available with euro plug.

Vibrant light at any time



Michael Raasch, 2018



POM

SHALLOW

Layers create depth: that's the story of Shallow in three words. This big rug reflects the trend towards round, organic interior forms, achieving its unique effect by combining colours to make them seem transparent. The four areas of colour are also staggered, creating a unique feeling of depth that's like looking down into the clear water of a pond.

Claire Vos, 2022

Claire Vos's beautiful cushion for PODE is inspired by puffy dresses, and was created to meet her own need for a slightly smaller cushion. The result was the compact Chillow, measuring 50 by 35 centimetres and with a supremely elegant finish. It's available in all PODE materials, including fabric, real and artificial leather, and non-wovens. With its cuddly round shape, it's a must-have accessory - as Claire puts it, your best friend in the living room.

Claire Vos, 2022



CHILLOW

PODE

119

With Cord it's easy to add a comfortable cushion to your interior that's a perfect match for all your other Pode products. You can actually order these cushions in all upholstery fabrics from our collection. There are three different sizes, 60 cm x 50 cm, 60 cm x 40 cm and 80 cm x 30 cm. The elongated size of the latter cushion makes it ideal for use as a lower back cushion. For an additional accent, you can also choose another fabric or contrasting colour for the Cord's wonderfully thick piping.



CORD

Studio KZ15, 2020

NASTRO

Claire Vos, 2020



A stylish
ribbon

With Nastro, Claire Vos created a wonderful addition to the Pode rug collection. The sleek lines give the impression that a folded ribbon is incorporated into the rug. Hence the name, because Nastro means ribbon in Italian. Moreover, each design surface has a different structure and emphasis, which gives Nastro an interesting depth.

RYE



Maghalie Doods, 2018



The Rye rug series is Belgian designer Maghalie Doods' first design for PODE. Each rug is handwoven from 100% wool. You can choose from different colours and sizes, so you can be certain that there's always a Rye rug that is a perfect match for your style and room.

PUFF

Claire Vos, 2017

A real drape-it-anywhere cushion



Puff is the ideal accessory if you need to recharge your battery. A real drape-it-anywhere cushion that you can comfortably nestle in. Nice and big, nice and soft, and the perfect company. Casually finished with generous strips of fabric along the sides for even more grip.

Take some wonderful cotton chenille, a beautiful tuft of wool and a huge dose of 70s retro. These are just the right components for Punto; an enchanting rug, designed by Claire Vos. Punto pampers you with an abundance of circles that together form a beautiful composition. The ideal foundation for a living room full of stylish ambience.



PUNTO

Claire Vos, 2017

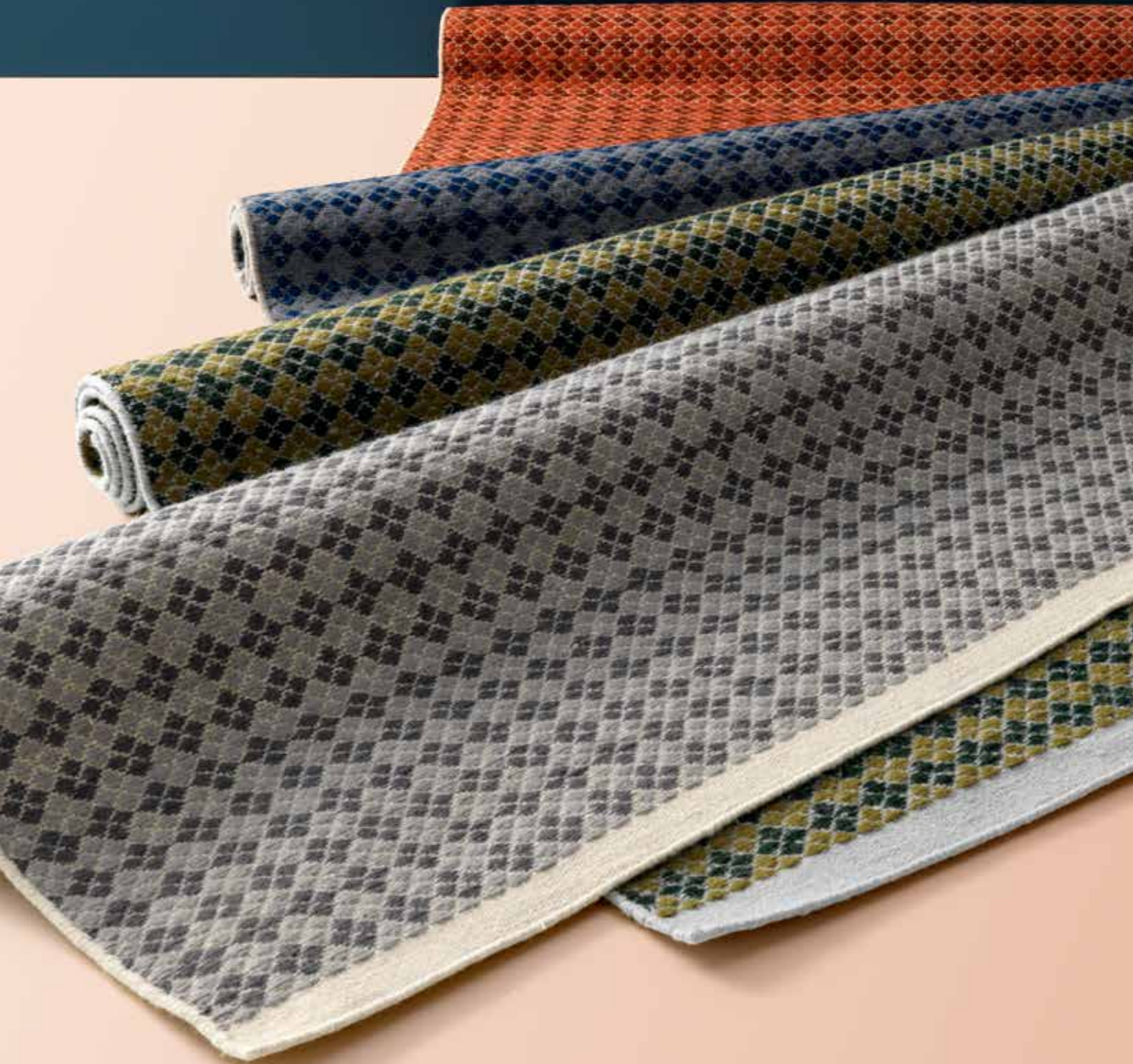

Mackay is never out of style thanks to the timeless pattern based on the classic Scottish Argyle tartan. Bring the Highlands a little closer with this roughly woven carpet in the sizes Medium (180x240 cm), Large (200x300 cm) and Oval (200x300 cm).

It's time for glamour, warmth and style. With this Swell series, which is Art Deco inspired, every sofa is transformed into an inviting and attractive place to relax. The jacquard fibres are characterised by strong dynamic lines made up of geometric patterns, such as circles and vertical lines. Combined bright colours or indeed warm deep tones such as mustard, turquoise, and red tints set the tone.

It's time for glamour,
warmth and style



With the Tab decorative cushion, you will add an extra dose of frivolity to your interior. The series is recognisable by the whimsical flat piping on the sides. The trim on the Tab is very flexible, so you can mix and match to your heart's content!



Pure in colour and texture

Materials and upholstery

Materials make your Pode personal

The materials of your furniture will live with you for years. And that is why we give you all the space you need to choose exactly what suits you. You can see that, for example, in our upholstery collection. The many high-quality fabrics and leathers offer you a universe of colours and textures.

Once you have found your favourite upholstery, you can complete your sofa or armchair with a beautiful colour of lacquer or powder coating for the legs or frame. It is precisely with these choices that you make your furniture truly personal.

With our tables, too, discovering the materials is a treat. Depending on the model, you can choose oak, ceramic or marble. And for many tabletops, a lacquered top is also an option.





FABRICS

Balance <small>(not available in all international markets)</small>						
	<i>Bean</i>	<i>Cream</i>	<i>Rice</i>	<i>Com</i>	<i>Carrot</i>	<i>Wine</i>
			Beams <small>(not available in all international markets)</small>			
<i>Kiwi</i>	<i>Ice Cube</i>	<i>Blackberry</i>		<i>Arctic</i>	<i>Lunar</i>	<i>Shore</i>
<i>Canola</i>	<i>Tundra</i>	<i>Wave</i>	<i>Meso</i>	<i>Pine</i>		
				Essential		
<i>Graphic</i>	<i>Urban</i>	<i>Steppe</i>	<i>Taiga</i>		<i>Egret</i>	<i>Peyote</i>
<i>Nimbus</i>	<i>Aragon</i>	<i>Paloma</i>	<i>Frost</i>			
			Evla			
<i>Anthracite</i>	<i>Allure</i>	<i>Saragosso</i>		<i>Light blue</i>	<i>Blue</i>	<i>Dark blue</i>
<i>Dark green</i>	<i>Light green</i>	<i>Maroon</i>	<i>Dark red</i>	<i>Red</i>	<i>Pink</i>	

FABRICS



FABRICS



FABRICS

Re-Wool						
	828	718	768			
Sotega <small>(not available in all international markets)</small>						
	Fuchsgold	Marone	Schoko	Smoke	Hellbeige	Carmin
Forest						
	Forest	Ocean	Lichtgrau	Platin	Anthrazit	Schwarz
Steelcut Trio						
	213	253	616	416	645	453
						
	946	153	996	883	776	796
						
	124					
Tweed <small>(not available in all international markets)</small>						
	Concrete	Gravel	Sedge	Aquatic	Kombu	
						
	Steel	Heron	Brindle	Graphite		

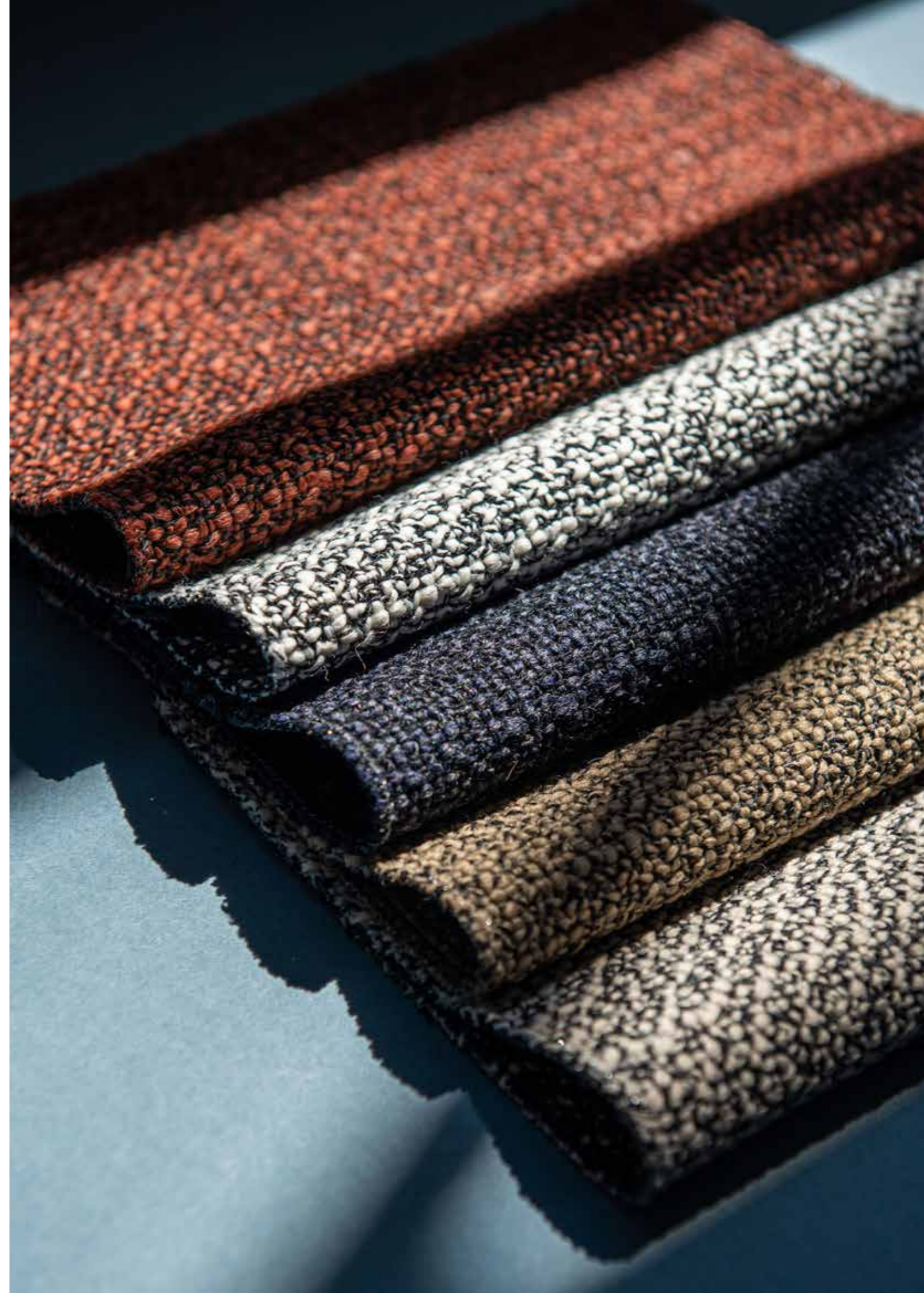



LEATHER

Fusion								
	<i>Flour</i>	<i>Potato</i>	<i>Shiitake</i>	<i>Mushroom</i>	<i>Toffee</i>	<i>Brownie</i>	<i>Bean</i>	
	<i>Fennel</i>	<i>Thyme</i>	<i>Cucumber</i>	<i>Aqua</i>	<i>Bois</i>	<i>Truffle</i>	<i>Raspberry</i>	<i>Grape</i>
	<i>Blush</i>	<i>Chile</i>	<i>Goji</i>	<i>Garnet</i>	<i>Salsito</i>	<i>Honey</i>		
	Neron							
<i>Brown Sugar</i>		<i>Cinnamon</i>	<i>Vanilla</i>	<i>Cocoa</i>	<i>Chia</i>	<i>Sage</i>		
<i>Sesame</i>		<i>Cumin</i>						
Perle								
		<i>Suit</i>	<i>Spruce</i>	<i>Moss</i>	<i>Salba</i>	<i>Medal</i>	<i>Rustic</i>	
	<i>Saddle</i>	<i>Cloud</i>	<i>Cobble</i>	<i>Gris</i>				

WOOD & LACQUER

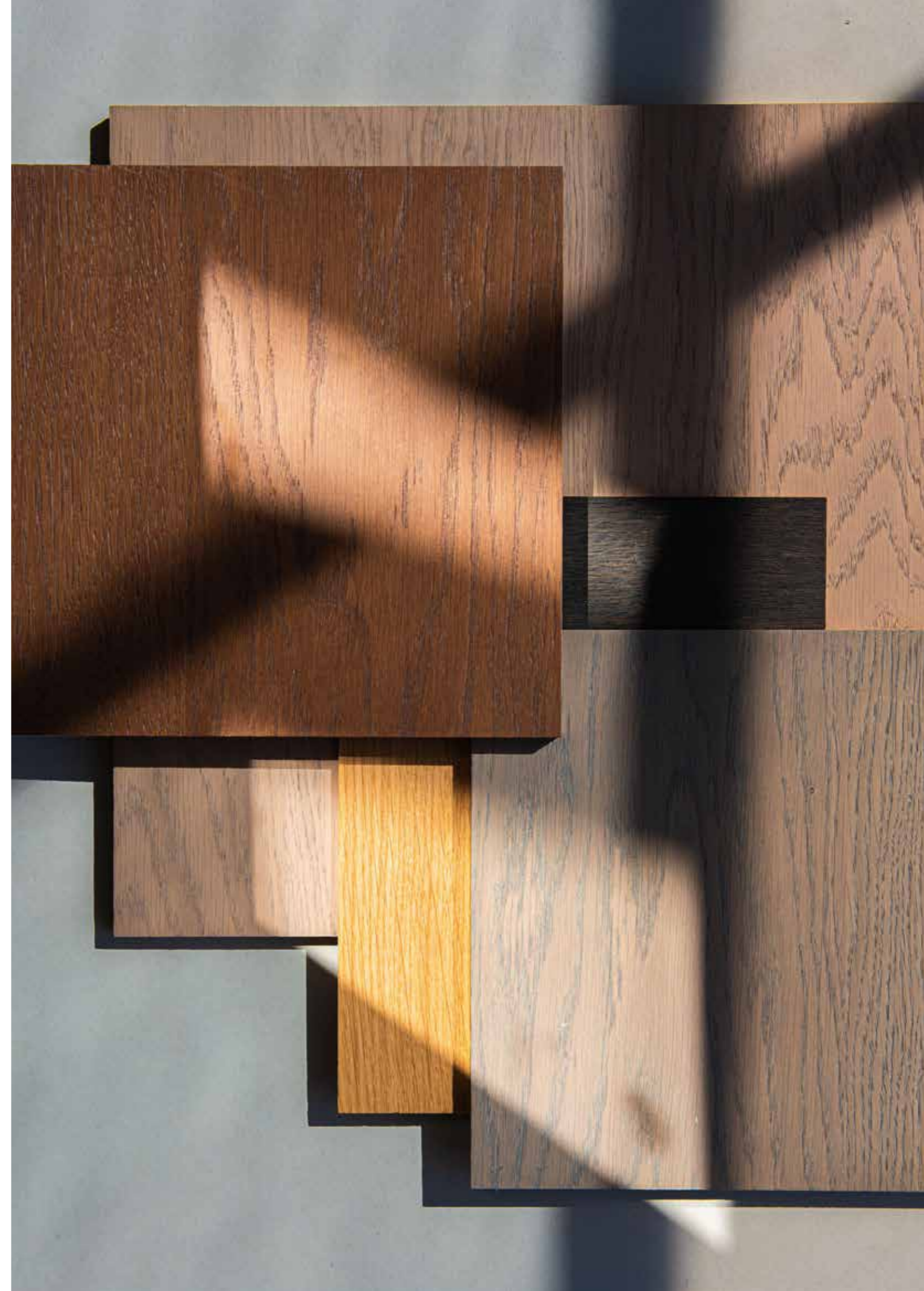

CERAMIC, MARBLE COMPOSITE & EPOXY



Ceramic



Glacier White



Retrostone



Concrete



Riverstone



Basalt

Marble composite



Calacatta



Fior di Pesco



Verde Tirreno



Grigio Carnico

Epoxy



Taupe



Nuit



Lava



Anodic

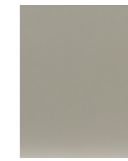

Space



Shell



Alpaca



Lead



Khaki



Raven



Your Pode's size

Technical information

Sofas



COLLA
Susanne de Graef



EDIT / INSERT
Jet Dircks



FOLD
Roderick Vos



OVA
Meike Harde



TRIPOD
Stephan Veit



TUBBLE
Roderick Vos



MARV
Roderick Vos



MELLOO
Roderick Vos



NIVTI
Meike Harde



TURIA
Yonoh

Lighting

(not available in all international markets)



OSUN
Michael Raasch



POM
Michael Raasch



PYLAZ
Michael Raasch

Armchairs



BIBO
Roderick Vos



CABUT
Yonoh



CHAP
Federica Biasi

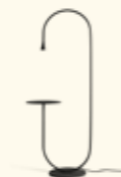

UTURN
Michael Raasch

Accessories



MACKAY
Claire Vos



NIHAN
Pascal Bosetti



SPARKLE ONE
Thijs Smeets



SPARKLE TWO
Thijs Smeets



SPOT ONE
Thijs Smeets



NASTRO
Claire Vos

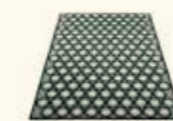

PUNTO
Claire Vos



RYE
Maghalie Doods



SHALLOW
Claire Vos



SPOT TWO
Thijs Smeets



TRANSIT ONE
Roderick Vos



TRANSIT TWO
Roderick Vos



TRESTO
Yonoh



SWELL
Claire Vos



UNDA
Meike Harde



CHILLOW
Claire Vos

Tables



BOTTLE STOOL
Kranen/Gille



JOLT
Yonoh



MESH
Raw Color



CORD
Studio KZ15



PUFF
Claire Vos



TAB
Studio KZ15

Sofa programmes

FOLD

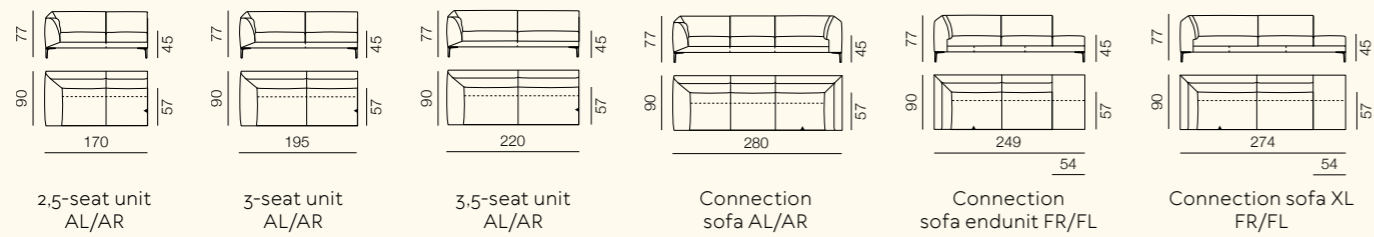
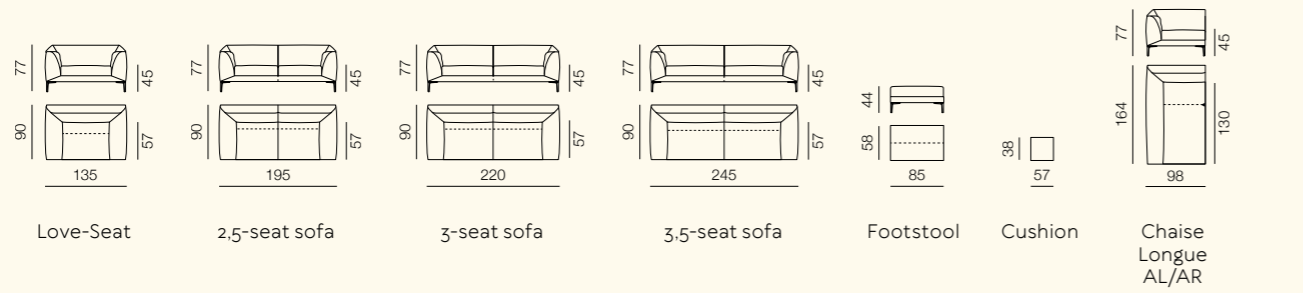

EXAMPLES

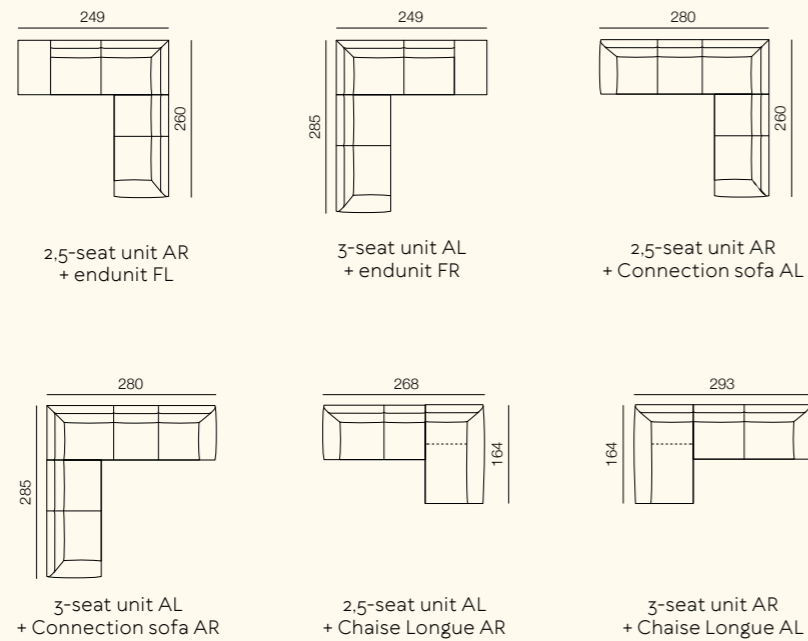

Scan the QR code for more information about Fold.

Find Fold on p. 76 - 81 of this magazine.

INSERT

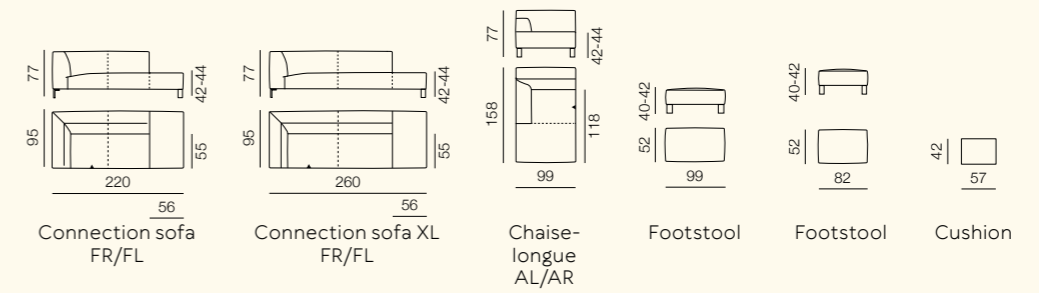
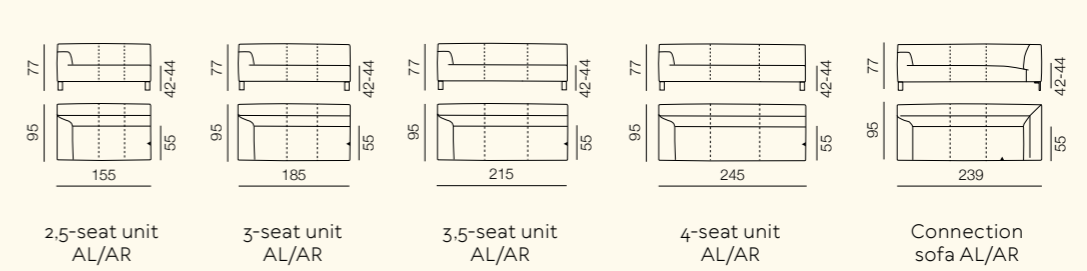

EXAMPLES

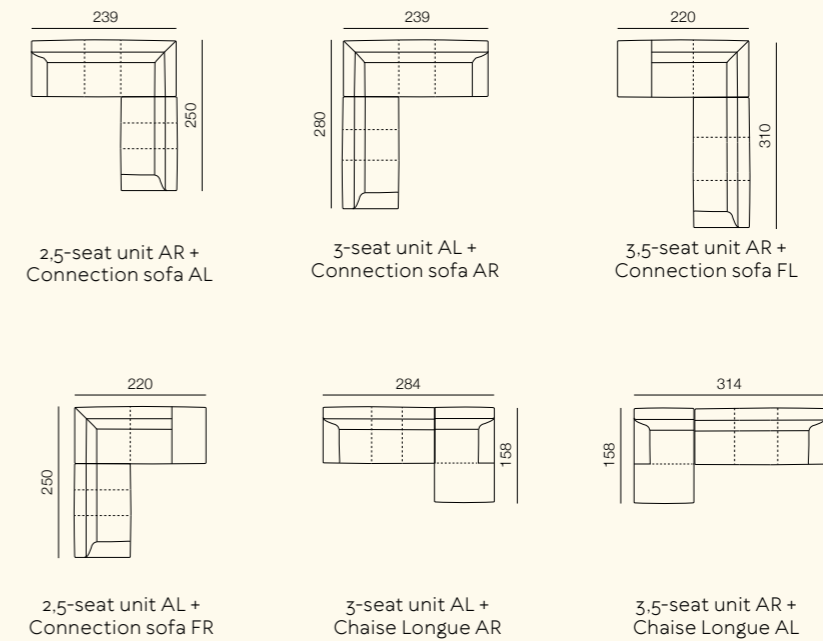

Scan the QR code for more information about Insert.

Find Insert on p. 102 - 105 of this magazine.

Sofa programmes

MELLOO

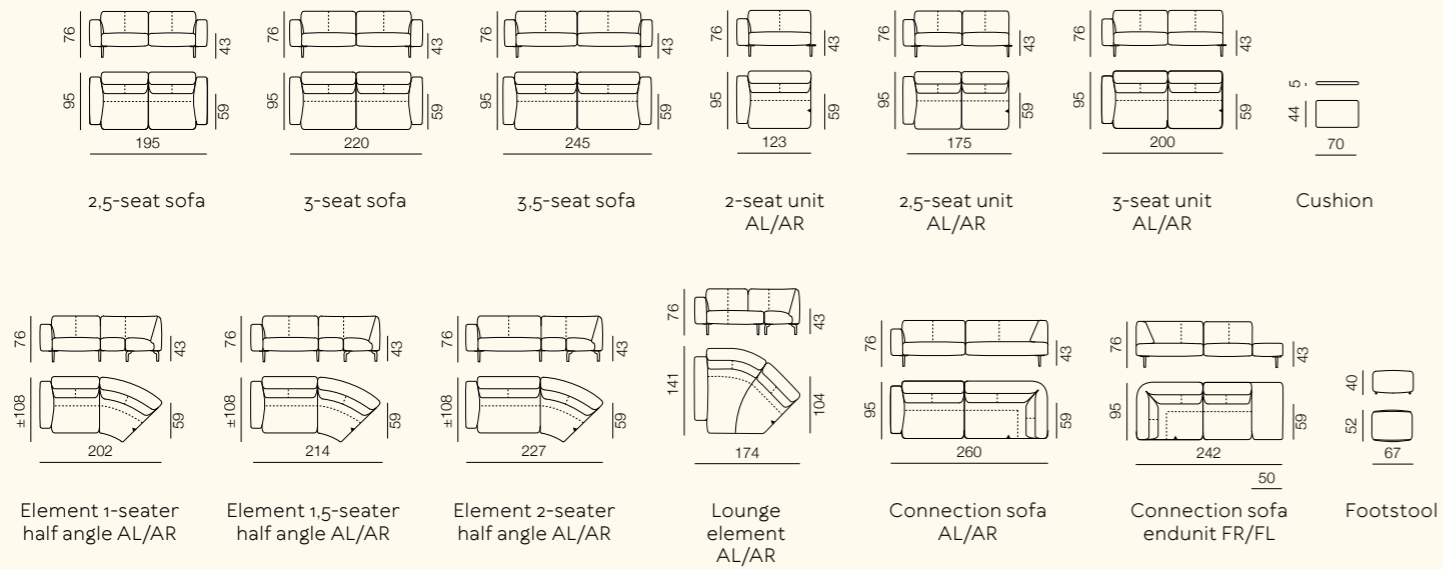

EXAMPLES

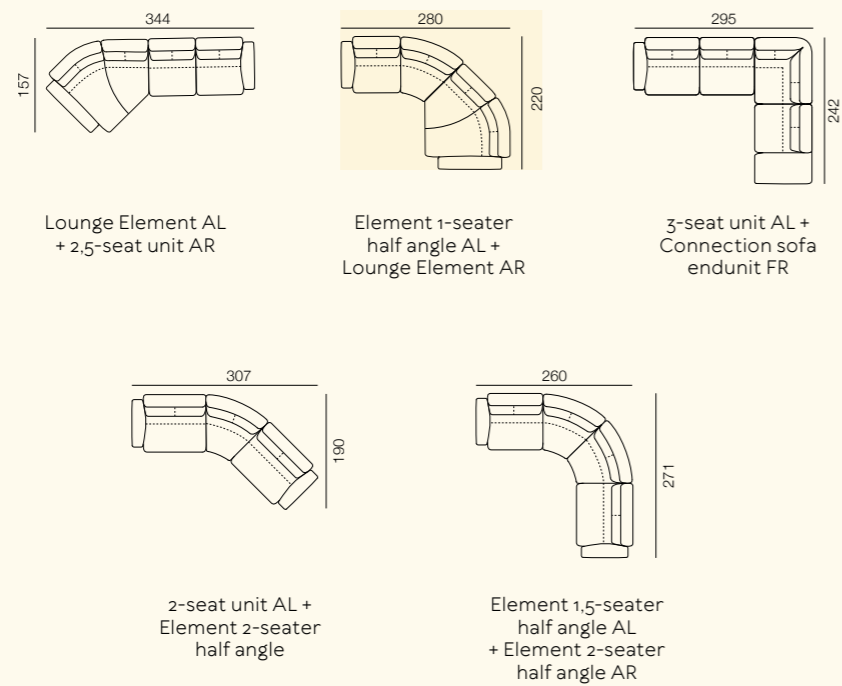

Scan the QR code for more information about Melloo.
Find Melloo on p. 106 - 109 of this magazine.

NIVTI

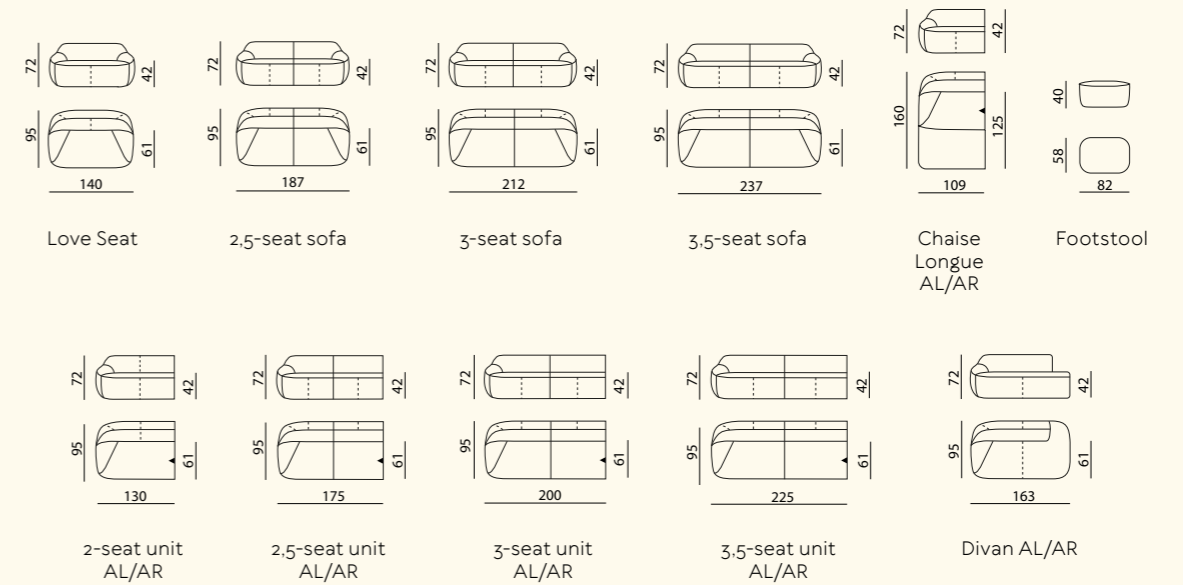

EXAMPLES

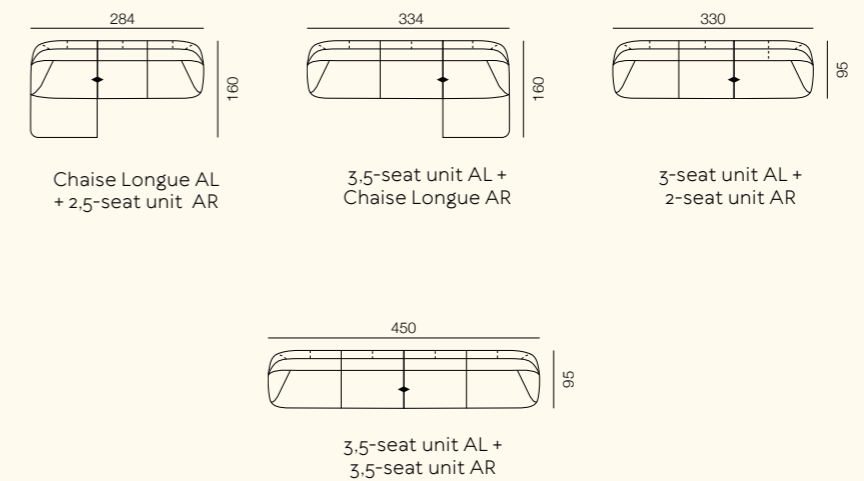

Scan the QR code for more information about Nivti.
Find Nivti on p. 18 - 23 of this magazine.

Sofa programmes

TURIA

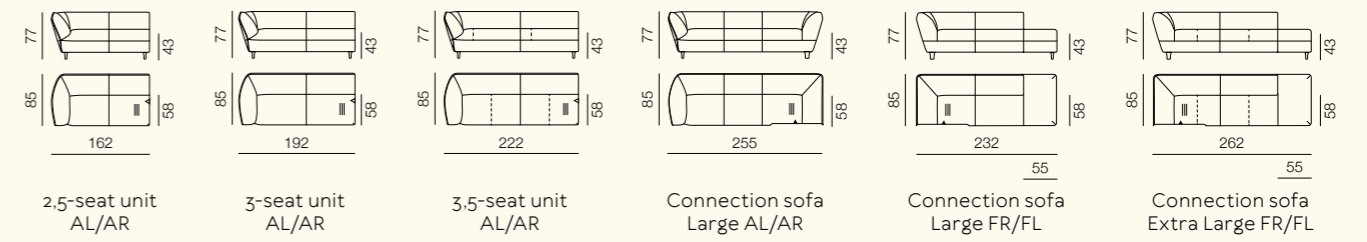
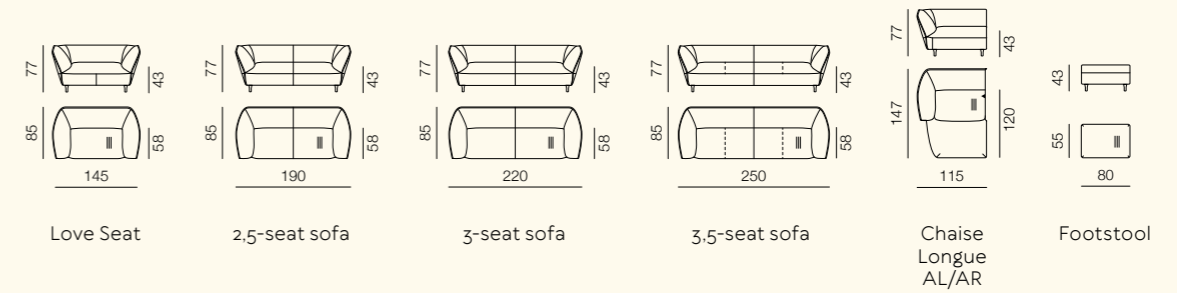

EXAMPLES

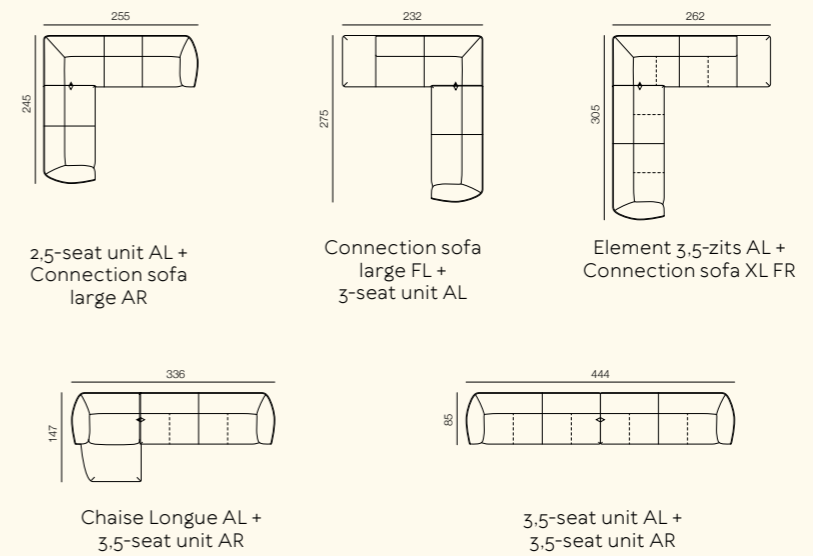

Scan the QR code for more information about Turia.

Find Turia on p. 54 - 59 of this magazine.

Sofas

COLLA

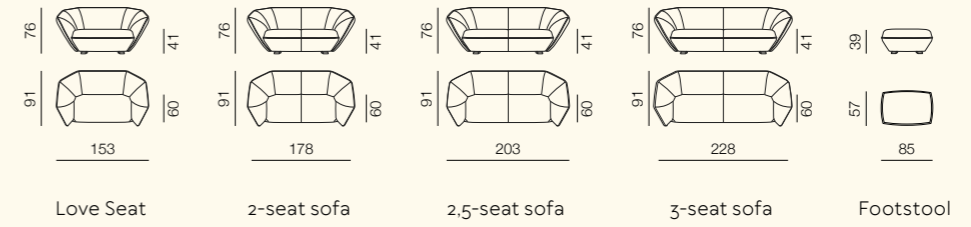

Scan the QR code for more information about Colla.

Find Colla on p. 70 - 71 of this magazine.

EDIT

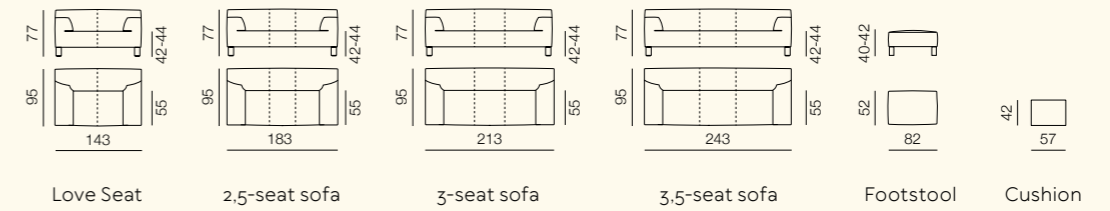

Scan the QR code for more information about Edit.

Find Edit on p. 98 - 101 of this magazine.

MARV

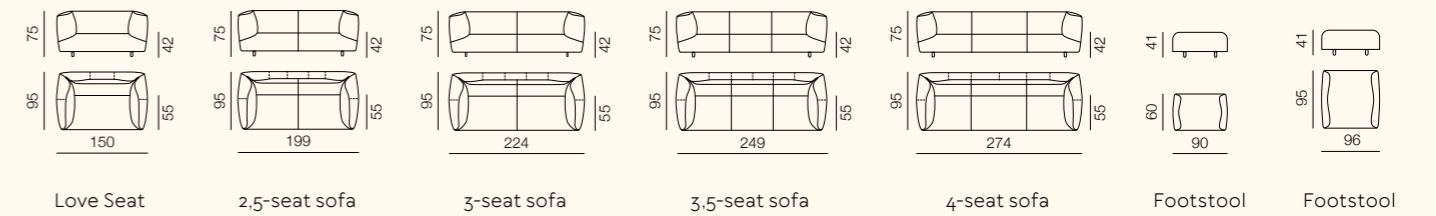

Scan the QR code for more information about Marv.

Find Marv on p. 38 - 43 of this magazine.

Armchairs

BIBO



Armchair Footstool



Scan the QR code for more information about Bibo.

Find Bibo on p. 72 - 75 of this magazine.

CABUT

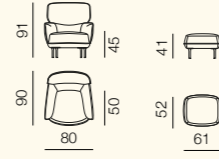

Armchair Footstool



Scan the QR code for more information about Cabut.

Find Cabut on p. 60 - 61 of this magazine.

CHAP

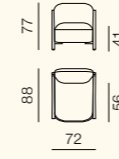

Armchair



Scan the QR code for more information about Chap.

Find Chap on p. 44 - 47 of this magazine.

NIHAN

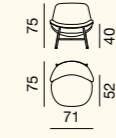

Armchair



Scan the QR code for more information about Nihan.

Find Nihan on p. 92 - 93 of this magazine.

SPARKLE

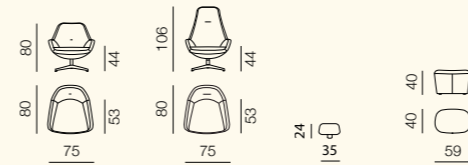

Armchair One Armchair Two Head cushion Footstool



Scan the QR code for more information about Sparkle.

Find Sparkle on p. 82 - 83 of this magazine.

SPOT

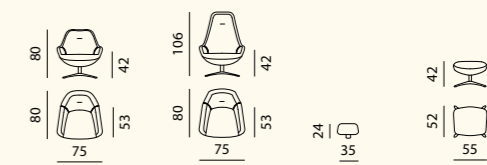

Armchair One Armchair Two Head cushion Footstool



Scan the QR code for more information about Spot.

Find Spot on p. 84 - 85 of this magazine.

TRANSIT

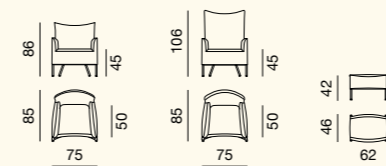

Armchair One Armchair Two Footstool



Scan the QR code for more information about Transit.

Find Transit on p. 110 - 111 of this magazine.

TRESTO

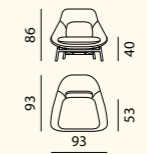

Armchair



Scan the QR code for more information about Tresto.

Find Tresto on p. 26 - 31 of this magazine.

BOTTLE STOOL



Occasional table



Scan the QR code for more information about Bottle Stool.

Find Bottle Stool on p. 94 - 95 of this magazine.

JOLT

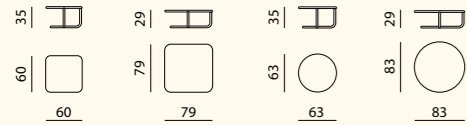

Coffee table Coffee table Coffee table Coffee table



Scan the QR code for more information about Jolt.

Find Jolt on p. 32 - 35 of this magazine.

MESH

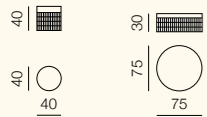

Occasional table Coffee table



Scan the QR code for more information about Mesht.

Find Mesh on p. 48 - 53 of this magazine.

Tables

OVA

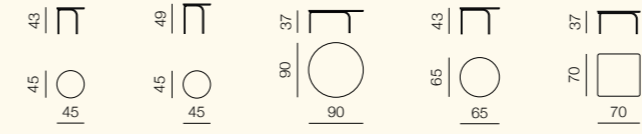

Occasional table Occasional table Coffee table Coffee table Coffee table



Scan the QR code for more information about Ova.

Find Ova on p. 86 - 89 of this magazine.

TUBBLE

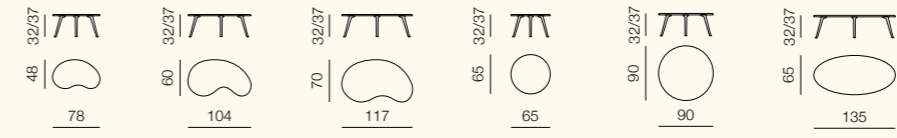

Coffee table Coffee table Coffee table Coffee table Coffee table Coffee table



Scan the QR code for more information about Tubble.

Find Tubble on p. 62 - 65 of this magazine.

TRIPOD

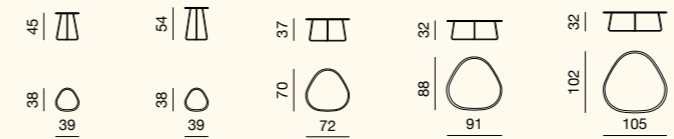

Occasional table Occasional table Coffee table Coffee table Coffee table



Scan the QR code for more information about Tripod.

Find Tripod on p. 96 - 97 of this magazine.

MACKAY

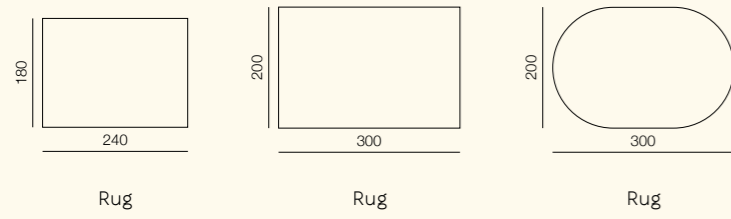

Scan the QR code for more information about Mackay.
Find Mackay on p. 126 of this magazine.

NASTRO

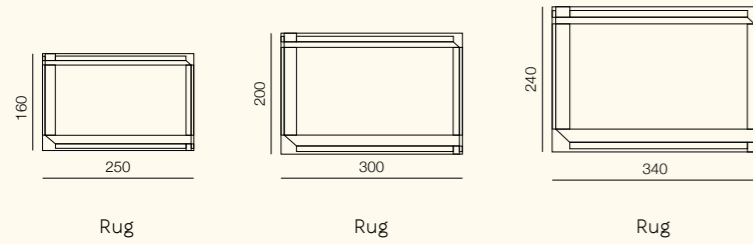

Scan the QR code for more information about Nastro.
Find Nastro on p. 121 of this magazine.

Rugs

PUNTO

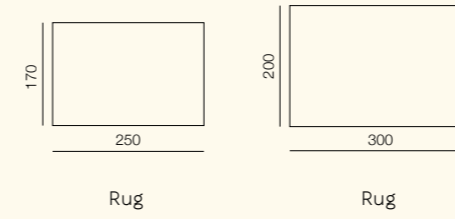

Scan the QR code for more information about Punto.
Find Punto on p. 125 of this magazine.

RYE

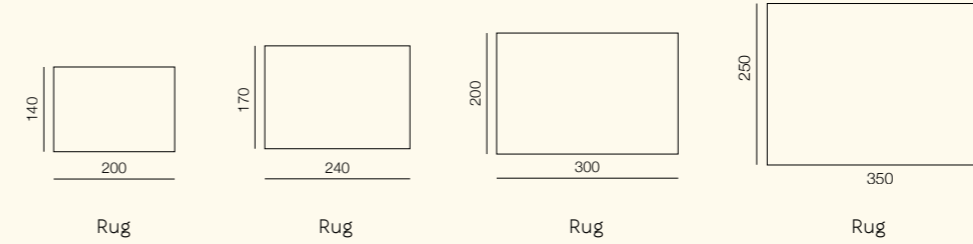

Scan the QR code for more information about Rye.
Find Rye on p. 122 of this magazine.

SHALLOW

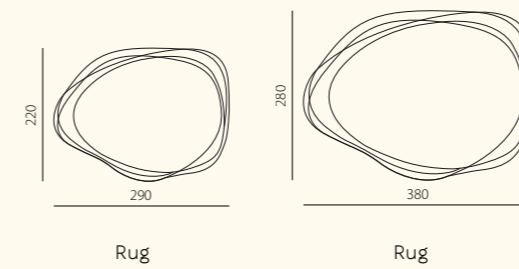

Scan the QR code for more information about Shallow.
Find Shallow on p. 118 of this magazine.

OSUN

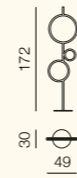

Lamp



Scan the QR code for more information about Osun.

Find Osun on p. 116 of this magazine.

POM



Lamp



Scan the QR code for more information about Pom.

Find Pom on p. 117 of this magazine.

PYLAZ

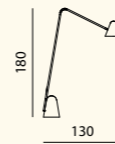

Lamp



Scan the QR code for more information about Pylaz.

Find Pylaz on p. 115 of this magazine.

UTURN

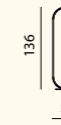

Lamp



Scan the QR code for more information about Uturn.

Find Uturn on p. 114 of this magazine.

Accessories

SWELL

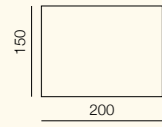

Plaid



Scan the QR code for more information about Swell.

Find Swell on p. 127 of this magazine.

UNDA

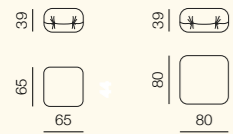

Footstool

Footstool



Scan the QR code for more information about Unda.

Find Unda on p. 90-91 of this magazine.

CHILLOW



Cushion



Scan the QR code for more information about Chillow.

Find Chillow on p. 119 of this magazine.

PUFF

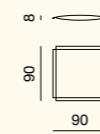

Cushion



Scan the QR code for more information about Puff.

Find Puff on p. 124 of this magazine.

CORD

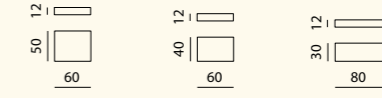

Cushion

Cushion

Cushion



Scan the QR code for more information about Cord.

Find Cord on p. 120 of this magazine.

TAB

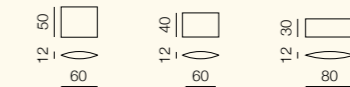

Cushion

Cushion

Cushion



Scan the QR code for more information about Tab.

Find Tab on p. 128 of this magazine.



SERVICE & GUARANTEE

We deliver our products in good condition. Needless to say, our follow-up service extends much further. A top brand such as Pode naturally has an outstanding service and guarantee scheme.

What do we do?

Pode delivers perfect products and we want to keep it that way. If, despite the great care that we take, anything should go wrong in the first 2 years, a 100% guarantee scheme applies.

Visit www.pode.eu. The full guarantee scheme is displayed there.

What can you do yourself?

All upholstery, both fabric and leather, comes from top suppliers. And everything has been extensively tested for strength and colour fastness. So it lasts a really long time. But you too can contribute to this by taking good care of the upholstery. You can find some handy tips on www.pode.eu.

COLOPHON

This magazine is a Pode publication (collection 2023)

Chief editors:

Leolux Furniture Group | Claire Vos

Art Direction:

Studio Roderick Vos

Design:

Raw Color

Text:

Ben Salden | Antal Németh

Photography:

Benning & Gladkova
Assistent fotografie Tim Posthumus Meyjes & Ivan Lopez
Maas
Marthe Bodil Vos & Kilian Marie Vos

Styling and production:

Studio Roderick Vos | Assistent Julia Jacobs

Styling:

Studio Roderick Vos | Studio Roderick Vos | Kamer 465

Image editing:

Benning & Gladkova | Peer Coopmans

3D:

Khomatech

Portrait photography:

Alexander Popelier | Benning & Gladkova

Product photography:

Zebra Fotostudio's | Peer Coopmans

With thanks:

oode.nl | arnohoogland.com | still-olga.nl | willemvhooff.com | studiorens.com | dawnbendick.squarespace.com | muset.design | deploeg.com | kvadrat.dk | forbo.com

Models:

Jacobus Benning | Micky van Esveld | Alicia Anais Fuentes | Ofri Geertjes | Laura Hoek | Julia Jacobs | Jorinde Kirsten | Fieke Klerkx | Benjamin Sacks | Kilian Vos | Marthe Vos | Nini van der Waals | Joep van der Zalm

Hier kun je Pode vinden:

Leolux Experience Center Breukelen (NL)

De Corridor 9A
3621 ZA Breukelen
+31 (0)30-2938149
experiencecenter@leolux.nl

Leolux Design Center Krefeld (D)

Elbestraße 39
47800 Krefeld-Gartenstadt
+49 (0) 2151 94 36 0
krefeld@leolux.de

Leolux Design Center Sint-Pieters-Leeuw (B)

Bergensesteenweg 423A
1600 Sint-Pieters-Leeuw
+32 (0) 2 331 27 70
info@leolux.be

